



VERIMATIC VS1000

Vertical awning with motor

VS1000



	min. 85 cm max. 300 cm		min. 80 cm max. 350 cm
--	---------------------------	--	---------------------------

Description

Vertical awning with motor drive. Fabric cover. Direction from bottom to top or from top to bottom. Rising and lowering of the awning with tubular AC motor 220/230V with friction brake and electronic end stop. Thermal protection. Protection class IP54 (splash water), with 0.8m 4-pole connection cable. Box: extruded aluminium profiles, in one piece, round, as a construction support element, including profile groove for the rubber to seal the box. Side caps with integrated gudgeon for plug-in link made of aluminium for the roller tube bearing or the motor bearing. Roller tube made of galvanised steel with groove for the cover fixation. Front rail made of extruded aluminium chamber profile, with profile tab to seal the protection box, with grooves for the cover and the driver of the pull and push mechanism. With rolled in front rail, the box is completely closed. Guide rails made of extruded aluminium profiles, with slide groove for the plastic gliders, hollow chamber for the integrated gas-filled strut mechanism and stainless steel cable tension system for the cover transport as well as profile groove for the fixation.

Option electric drive: Tubular AC motor 230V/50Hz with friction brake and electronic end stop. Thermal protection. Protection class IP54 (splash water), with 50-150cm 4-pole connection cable.

METHOD OF DELIVERY

With box profile: Awning completely assembled
With cover, guide rails separately





VERIMATIC VS1000

Vertical awning with motor

VS1000

Wall fixing

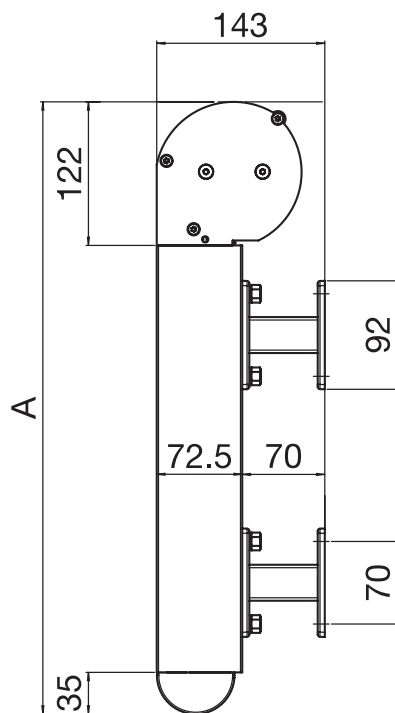
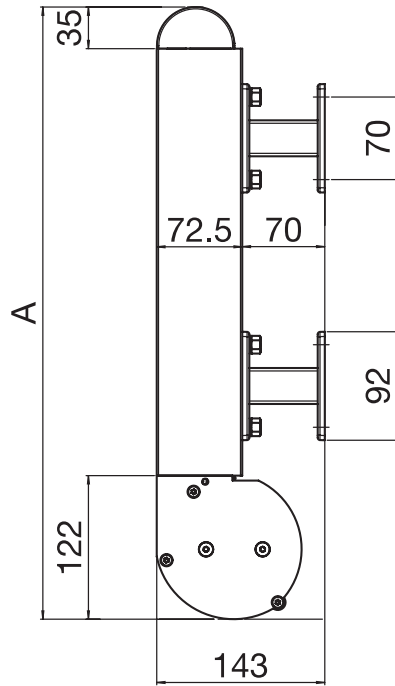

A = Total height



VERIMATIC VS1000

Vertical awning with motor

VS1000

Installation drawing

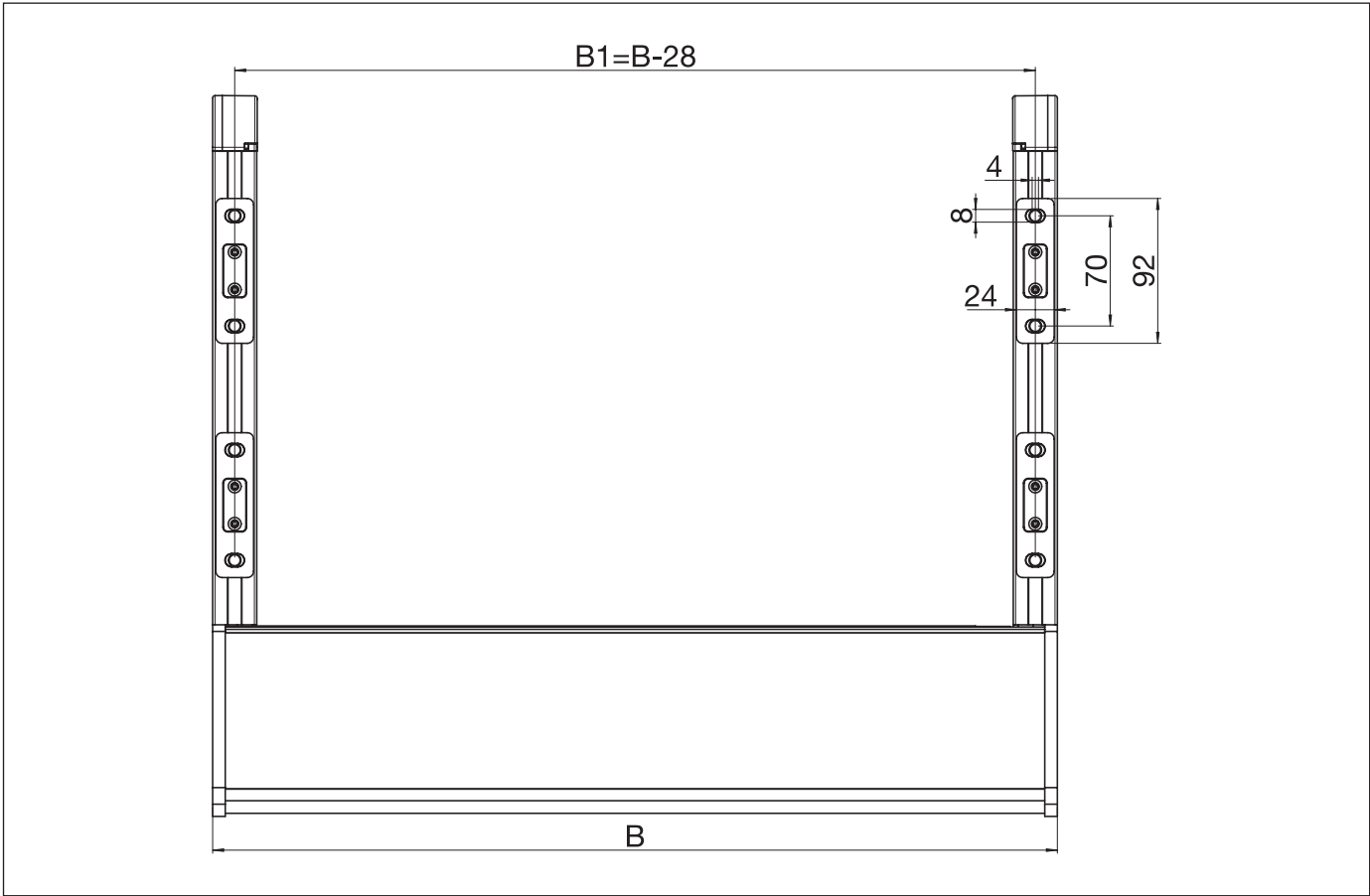

B = Total width